



*Review paper*

UDC: 911.2:504:628.1  
DOI: 10.2298/IJGI1401023V

## DEVELOPMENT AND IMPLEMENTATION OF ECOLOGICALLY SAFE TECHNOLOGIES OF OBTAINING DRINKING WATER

*Alexey L. Vasiliev* <sup>\*1</sup>, *Lev A. Vasiliev* <sup>\*</sup>, *Irina V. Bokova* <sup>\*</sup>

<sup>\*</sup> Nizhny Novgorod State University of Architecture and Civil Engineering (NNGASU)

Received 12 December 2013; reviewed 28 January 2014; accepted 09 April 2014

**Abstract:** This article presents ecologically safe technologies and devices for drinking water treatment which can be used in megalopolices, small settlements and also in emergency cases.

**Key words:** water treatment, drinking water, ozonization

### Introduction

Water is natural humane heritage, necessary condition of humane life. Providing population with pure drinking water contributes achieving of the main goal – improving and preservation of public health and nation safety in general.

The reasons for aggravation of problems of water supply are connected with qualitative and quantitative aspects of water resources state, increasing volume of water consumption and intensified anthropogenic pollution of water sources.

There's an opinion existing in Russia and abroad that many treatment systems are not a barrier to the whole range of water contaminants – hydrobionts, organic substances, ions of heavy metals, viruses. In addition during traditional water treatment with prechlorination, coagulation, sedimentation, filtration, postchlorination a class of substances relating to volatile halogenated organic compounds (VOCs) containing trihalomethane are generated.

The urgency of the problem is also confirmed by the fact that many scientists work on improving the water treatment technologies and search for new methods of water treatment (Sung-Ryong, 2004; Aktas, 2006).

The chair of water supply and sewage of NNGASU also work on the development of ecologically safe technologies for obtaining drinking water in the following directions:

---

<sup>1</sup> Correspondence to: vasilievlev@rambler.ru

- development of technologies of water treatment for big cities with the use of equipment for biological pretreatment;
- development of technologies and equipment of water treatment for small settlements;
- development of technologies and equipment of water treatment for obtaining drinking water in emergency cases.

The analysis of prior information and our investigations let us make a conclusion that ozonation is one of the perspective methods of water treatment. The high effectiveness of ozone while using it as a primary oxidizing agent confirms its universality, ecological friendliness and feasibility of its application in modern technologies of water treatment (Vasiliev, 2007).

Chlorine compounds, particularly chloroform, in drinking water are dangerous for public health, as the results of field observations and experimental studies indicate a general toxic action and long-term effects of carcinogenicity and mutagenicity. The studies found that drinking water contains a large number of synthetic organic compounds the content of which is about several hundredths or even several tenths of milligrams per liter (Table 1).

In a study of one of the water treatment stations operating according to the scheme of primary chlorination - coagulation - sedimentation, filtration - secondary chlorination it was found that drinking water contains concentration of chloroform 2 - 4 times higher than permissible limits.

Table 1. Chemical compound in water

Chemical compound in water	Natural water	Water from tap	Drinking water
Methyl chloride	0	0	20
Chloroform	0	0	115
Carbon tetrachloride	0	5	8
Dibromochloromethane	0	3	3
Bromdihlormetane	0	15	10
1,2-dichloroethane	5	5	5
trichloroethene	20	10	10
tetrachloroethene	6	6	7
1,2 - Dichloroethane	120	100	60
1,1,2 - Trichloroethane	6	6	5
1,1,2,2-Tetrachloroethane	45	35	30
Chlorobenzene	40	50	35
Total amount of volatile halogenated compounds	242	235	308

In order to prevent the formation of VOCs it is advised to consider the possibility of changing water treatment technology. A number of methods were suggested. The most important of them are the following:

- development of technology for water purification, providing the complete removal of hydrobionts in order to prevent secondary pollution of water in water supply systems;
- creation of devices which run using the properties of natural ecological community reservoirs and water to accumulate organic and other substances contained in natural water not only of natural origin but also man-made.

### **Methodology and results**

*(the technology of water treatment with the use of array of biological pretreatment)*

The authors have developed a method of water purification and models of devices for biological pretreatment by natural biocenose (bioabsorber) (Naidenko, 1991; Vasiliev, 2011).

Gained as a result of research on accumulating ability of the ecological community of water supply sources biocenose allowed, along with the use of ozone, ecologically pure and powerful oxidant, to obtain a highly effective technology and bring the solution to the problem of returning of natural properties to the drinking water

It was found out that the level of contamination of the water passing through bioabsorber is reduced by 20 - 60% depending on the type of contamination.

Basing on the studies the technology of natural water cleaning using biological pre-treatment installations (Figure 1) and the method of calculation of optimal modes of water treatment have been developed (Vasiliev, Kazakov, 2010).

At developing the methodology it was assumed that each component of the pollution entering the natural water is involved in the microscopic (molecular diffusion) and macroscopic (convection) and mass transfer in bioabsorber and is partially absorbed by biocenose fouling.

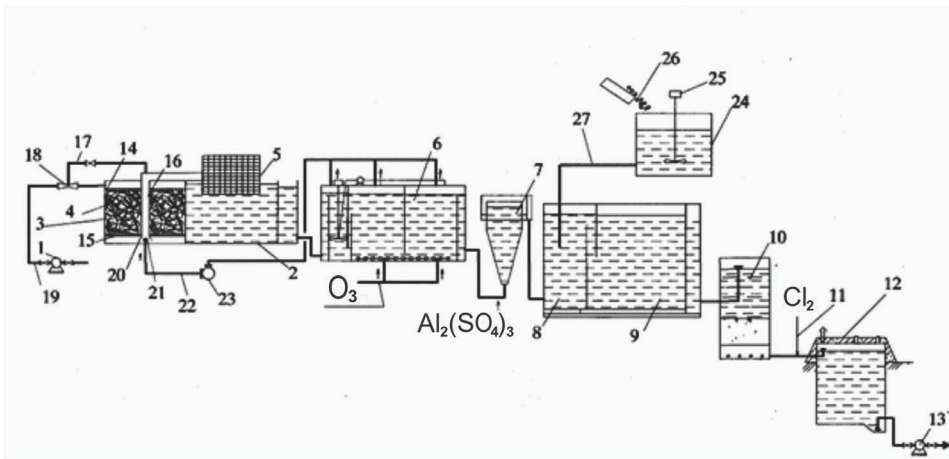

Figure 1. Technological scheme of water treatment with the use of array of biological pretreatment with flat nut elements

1 – pumping unit of the first lift; 2 – microfilter; 3 – reception channel of microfilter; 4 – volumetric nut element; 5- filtering cylinder; 6 - catalyst case of the first ozoning; 7-mixer; 8- flocculation chamber; 9- horizontal sedimentation tank; 10- fast non-pressure filter; 11- chlorine supply pipeline; 12 – clear water reservoir; 13- pumping unit of the second lift; 14- upper slot partition; 15- lower slot partition; 16- central pipe; 17- outlet branch; 18 – ejector; 19- inlet branch; 20- guiding element; 21 – spray nozzle; 22 – air duct; 23- compressor; 24 – coal slurry preparation tank; 25 – blunger; 26 – input of activated coal; 27 – pipeline of coal slurry supply to flocculation chambers.

Using Fick's law the masses of summarized carryover of the components are defined, and, expressing masses transferred through the projection of vector are expanded into Taylor series.

It's assumed that flowing of the water has "piston-like" nature; in this case the Peclet number is  $Pe \approx 108$ . In this case biochemical reactions proceed at the top of biocenose augmenting its mass and they are referred to heterogenic chemical reactions. That's why the equation of speed of response is formed only by concentrations of the materials presented in a solution.

For stationary process of carryover:

$$Pe \frac{\partial C_i}{\partial X} \cong -M_v^i \quad (1)$$

where:  $Pe$  – Peclet number;  $C_i$  – concentration of  $i$ - component;  $M_v^i$  – dimensionless density of internal mass flow of  $i$ -component.

Speed of response in proportion to concentration of parent substance, then for dimensional internal mass flow of i-component of water:

$$m_V^i = \gamma_i \cdot c_i - \frac{\beta_i}{w_0} \quad (2)$$

where:  $m_V^i$  - dimensional internal mass flow of i-component ;  $c_i$  – concentration of i-component;  $w_0$  – velocity of water flow.

Constant coefficients  $\gamma_i$ ,  $\beta_i$  for each i-component of water are defined experimentally. Equation (1) at marginal check  $x=0; c_i=c_{i0}$  in dimensions is:

$$w_0 \frac{d c_i}{d x} = -\gamma_i c_i + \frac{\beta_i}{w_0} \quad (3)$$

The solution of this differential equation with the use of Laplace transformation to variable  $x$  and differentiating it at  $x=L$  to  $w_0$  and at  $w_0=0,6$  m/sec lets to express one of the coefficients in the form:

$$\beta_i = \frac{c_{i0} \cdot \gamma_i^2 \cdot L}{\exp\left(\frac{\gamma_i L}{w_{0\vartheta}}\right) - 1 + \frac{\gamma_i L}{w_{0\vartheta}}} \quad (4)$$

Then if  $x=L$  and  $w_0=w_{0\vartheta}$ , we obtain:

$$\frac{c_{iL}}{c_{i0}} = \frac{1 - \exp\left(-\frac{\gamma_i L}{w_{0\vartheta}}\right) + \frac{\gamma_i L}{w_{0\vartheta}}}{\exp\left(\frac{\gamma_i L}{w_{0\vartheta}}\right) - 1 + \frac{\gamma_i L}{w_{0\vartheta}}} \quad (5)$$

Transcendental equation (5) for each of the indicators of water quality is done numerically relative to  $\gamma_i$ , and is substituted into equation (4) to find coefficients  $\beta_i$ .

Comparison of experimental and calculated data shows that these equations allow to carry out theoretical calculations of optimal modes of water treatment in bioabsorber with a high degree of confidence.

*The technology of water treatment using ozonation reactor*

One of the urgent tasks in the field of water treatment is the supply of smaller communities with drinking water

Implementation of ozone use in water practice demanded theoretical basis for the selection of rational constructions and water purification schemes for different quality water, generalizing experience gained and getting additional experimental material, a different approach to the treatment of drinking water for small settlements.

Implementation of the use of ozone in water practice demanded theoretical basis for the selection of rational constructions and water purification schemes for time-personal qualities, capture lessons and gain additional experimental material, a different approach to the drinking water of small population centers.

The results of research led to the development of water treatment technology for small capacity plants which can be implemented in both fixed and portable configurations.

The technology includes two-stage filtration to input ozone in three points: before the pre-filter, between a prefilter and filter, and after a filter. The studies were conducted on various sources (the rivers Volga, Oka, Gorky reservoir, peat lake) at different times of the year. Investigated indicators of purified water meet Sanitary Norms and Rules 2.1.4.1074-01.

To implement the technology the installation for water treatment using apparatus with joint ozonation and filtration processes have been developed (reactors "filter-ozone" figure 2) (Naidenko V., 1994). A mathematical model of this process has been developed (Vasiliev A., Sharova O., 2010). The process is treated as a multi-component system which can be characterized by the input variables, the values of impact to the system - factors and parameters - the results of system response.

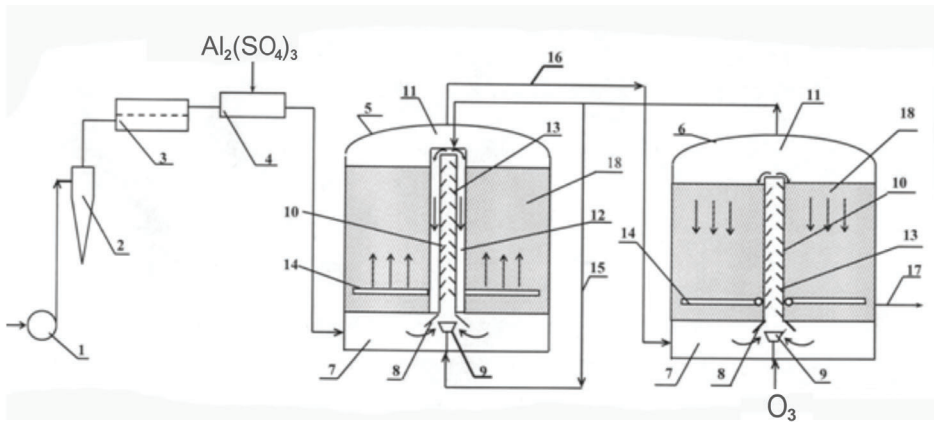

Figure 2. The technology of water treatment using ozonation reactor

- 1 – first-lift pump; 2 – hydraulic cyclone; 3 – microfilter; 4 – mixing device; 5 – preactor «filter-ozon»; 6 – reactor «filter-ozone» of the second stage; 7 – reactor chamber; 8 – cone; 9 – spray nozzle; 10 – central pipe; 11 – filtration chamber; 12 – inner hollow; 13 – turbulators; 14 – drainage system; 15 – air duct; 16,17 - air ducts ; 18 – filtering reactor loading

The method of presenting the response surface in the form of skeleton lines is used - the level of the surface, i.e. such lines which establish the relationship between the parameter and one of the factors of the process, at constant values of other factors.

The model allows determining the optimal values of the coagulant dose and doses of ozone (in the first and second points of entry) to the prediction of the quality of water treated by purification steps and at the end of technology. The criterion is the prediction of maximal parameters convergence input water standard for the considered stage of water treatment.

### *The production of drinking water in emergency situations*

More frequent natural disasters, terrorist acts happening recent years have shown that life support systems at vicinity of the accident including the system of water supply fail first, making it difficult to conduct rescue operations, they may cause unfavorable epidemiological situation and aggravate the situation even more. In war the effective solution of these issues may be one of the most important tasks in ensuring the success of combat operations. Providing civilians and troops with drinking water in various conditions of the military situation depends primarily on the capacity of the means used to accomplish this task (Koposov E., 2008; Koposov E., 2009).

Currently there are no effective small autonomous waste-water treatment devices. In connection with it there is a need for making autonomous small water treatment devices allowing obtaining safe drinking water from different sources in field conditions and emergency.

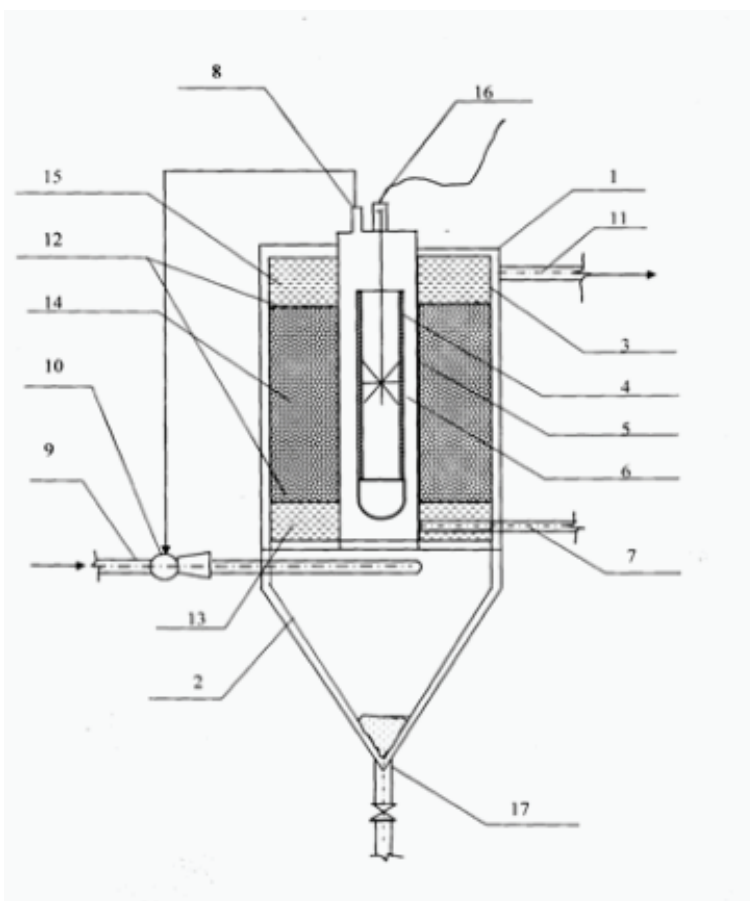

Figure 3. Water treatment installation

1- carcass; 2 – lower cone-shaped part of the carcass; 3 - cooling jacket; 4- high-voltage electrode; 5 – low-voltage electrode; 6 – discharge zone; 7 - the intake of compressed dry gas ; 8- ozone pipe; 9- intake of processed water; 10 - ejector; 11- ozonated water drainage pipe; 12 - nets; 13 – section of processed water; 14 - filter material cartridge; 15 - section of processed water; 16 high-voltage element

The analysis of the existing water treatment equipment used in emergency situations has shown that in most cases cleaning and decontamination of drinking water is based on traditional classical methods with all its flaws.



The authors have developed three installations for the production of drinking water in emergency situations (Vasiliev 2005; Naidenko 2007; Kuposov 2011). One of the developed installations is shown in Figure 3.

Feature of the given installations is a combination of processes of ozone synthesis and processing of water (ozone treatment and filtration). The installation includes the apparatus of water treatment, power management and automation, portable power source. At an output of 150 to 200 l/h weight not exceeding 12 kg.

### Conclusion

Suggested in the article installation with environmentally sound technologies for drinking water have been tested in the field conditions and confirmed its efficiency and reliability and are recommended for widespread implementation.

### References

- Sung-Ryong Ha, Suyodoa Vinitnantharat, Joshinobu Ishinobashi, J. Environ (2004). *Sci. Health*, p. 275 – 292.
- Aktas O., Cecen F. (2006). *Biotechnol. Chem. Technol*, 94 – 98.
- Kuposov E., Vasiliev A., Vasiliev L. (2008). Providing of qualitative water supply to population and special forces in emergency situations. *Privolzhsky Scientific Journal. N.Novgorod, № 2*, 13-24.
- Kuposov E., Vasiliev A., Vasiliev L. (2009). Block-module installations of drinking water treatment used in emergency situations. *Journal Innovation, St. Petersburg, № 3 (125)*, 45–47.
- Kuposov E., Vasiliev A., Vasiliev L., Bokova I., Sharova O. (2011). Water treatment installation. *Utility pat. 102 612 RF, C02F 1/78, C01B 13/11 Date of application 21.10.09, published 10.03.11, Bul. № 7*.
- Naidenko V., Vasiliev L., Vasiliev A., Dergunov E. (1994). Natural water treatment installation. *Pat. 2010014 RF, C 02 F 1/78. Date of application 17.06.91, published 30.03.94, Bul.№6*.
- Naidenko V., Vasiliev L., Vasiliev A., Dergunov E. (1991). Device for water treatment and the way of its implementation. *Pat. 1832119 RU, C 02/00. Date of application 17.06.91, published 0.7.08.93. Bul. № 29*.
- Naidenko V., Vasiliev A., Vasiliev L., Bokova I., Kroshilov A. (2007). Device for water treatment. *Pat. 2311348 RF, C02 F1/78. Date of application 03. 08.05, published 27.11.07, Bul. № 33*.
- Vasiliev A., Vasiliev L., Naidenko V. (2007) Ozon treatment of surface water. *Monograph. N. Novgorod, NNGU, 217*.

- Vasiliev A., Vasiliev L., Bokova I. (2011). Biological pretreatment in technologies of treatment of water for drinking purposes. *Monograph. N. Novgorod, NNGASU*, 1-118.
- Vasiliev A., Vasiliev L., Kazakov G., Bokova I. (2010). Theoretical basis of surface sources water treatment with the use of accumulation power of hydrobionts. *Privolzhsky Scientific Journal. N. Novgorod № 4*, 98–105.
- Vasiliev A., Vasiliev L., Bokova I., Sharova O. (2010). The development of mathematical model of the process of two stages filtration. *Privolzhsky Scientific Journal. N. Novgorod, 2010, № 3*, 89–95.
- Vasiliev A., Vasiliev L., Podgornova O., Bokova I. (2005). Device for ozon water treatment. *Pat. 2253609 RF, C 01 B 13/11, C 02 F 1/78. Date of application 24.06.04, published 10.06.05, Bul. № 16.*